

# 6000UR series

## Single, Dual, Triple Output DC/DC Converter



### DESCRIPTIONS

The 6000UR series is a family of 50W and 60W high performance DC/DC converters specifically designed for board mount power distribution applications where space is critical, but performance and power cannot be sacrificed. Standard features include an ultra wide 4:1 input voltage range, efficiency as high as 83%, input Pi filter, and continuous short circuit protection. 18 models operate over 4:1 input ranges of 9 to 36 or 18 to 72 VDC and provide tightly regulated output combinations of 3.3, 5, 12, 15,  $\pm 5$ ,  $\pm 12$ ,  $\pm 15$ ,  $5 \pm 12$  and  $5 \pm 15$  VDC.

### OUTPUT CHARACTERISTICS

	Min	Typ	Max	Unit/Comments
Output Voltage Accuracy				
Single & Dual Outputs			$\pm 1.0$	% <sup>1</sup>
Triple Outputs - Primary			$\pm 1.0$	% <sup>1</sup>
- Auxiliaries			$\pm 6.0$	% <sup>1</sup>
Output Voltage Adjustment				
3.3V Outputs			$\pm 100$	mV
All Other Models			$\pm 10.0$	% Output Voltage
Output Voltage Balance				
Dual Outputs			$\pm 2.0$	%; Equal Output Loads
Triple Outputs			$\pm 150$	mV; Equal Output Loads
Line Regulation - 3.3V Outputs			100	mV <sup>2</sup>
Single and Dual Outputs			$\pm 1.0$	% <sup>2</sup>
Triple Outputs - Primary			$\pm 1.0$	% <sup>2</sup>
- Auxiliaries			$\pm 6.0$	% <sup>2</sup>
Load Regulation - 3.3V Outputs			100	mV <sup>3</sup>
Single Outputs			$\pm 1.0$	% <sup>3</sup>
Dual Outputs			$\pm 1.0$	% <sup>3</sup> ; Equal Loads
Triple Outputs - Primary			$\pm 1.0$	% <sup>4</sup>
- Auxiliaries			$\pm 2.0$	% <sup>3</sup> ; Equal Loads
Ripple/Noise				mV; p-p <sup>5</sup>
3.3V and 5V Outputs			100	mV; p-p <sup>5</sup>
12V and 15V Outputs			1	%; p-p <sup>5</sup>
Triple Outputs - Primary			125	mV p-p <sup>5</sup>
Short Circuit Protection				Continuous, Automatic Recovery
Transient Recovery Time			250	$\mu$ S, to within 1% error band for 50% load step, 50% load to FL
Temperature Coefficient			$\pm 0.02$	% per °C
Over Voltage Protection				See Model Selection Guide

### FEATURES

- Efficiency to 83%
- Wide 4:1 Input Voltage Range
- Input Pi Filter
- Continuous Circuit Protection
- Wide -30°C to +75°C Operating Temperature Range
- Minimum 1400 VDC Input/Output Isolation
- >600,000 Hours MTBF

### INPUT CHARACTERISTICS

	Min	Typ	Max	Unit/Comments
Input Voltage Range				
24 VDC Input Models	9	24	36	VDC
48 VDC Input Models	18	24	72	VDC
Input Under Voltage Shutdown		8.5		VDC
Over Voltage Shutdown				
24 VDC Input Models		42		VDC
48 VDC Input Models		74		VDC
Input Fuse Requirement				
24 VDC Input Models		10		A; Slow Blow Type
48 VDC Input Models		6		A; Slow Blow Type
Reflected Ripple Current				See Model Selection Guide
Reverse Polarity Input Current			12	Amp
Input Filter				Pi Filter

### GENERAL CHARACTERISTICS

	Min	Typ	Max	Unit/Comments
Switching Frequency		125		kHz
Isolation Voltage		1000		VDC, 1 minute
Isolation Resistance		1000		Mohm, 500VDC
MTBF (MIL-HBK-217F)		600		Thousand Hours, +25°C, Ground Benign

<sup>1</sup> = Output voltage at nominal line & FL

<sup>2</sup> = % Output voltage measured from min. input line to maximum

<sup>3</sup> = Output voltage measured from FL to 25% Load

<sup>4</sup> = Output voltage measured from FL to no load

<sup>5</sup> = Nom. Line @ FL, 20 Mhz B.W. using 1  $\mu$ f bypass capacitor

## ENVIRONMENTAL SPECIFICATIONS

	Min	Typ	Max	Unit/Comments
Operating Temp. Range	-40		+71	°C; Ambient
Thermal Shutdown		95		°C; Case Temp.
Storage Temp. Range	-40		+125	°C
Relative Humidity			95	% Humidity; non-condensing
Cooling				Requires Heatsink and 400 LFM airflow

## PHYSICAL CHARACTERISTICS

	Unit/Comments
Case Size	2.56 X 3.00 X 0.75 inches (65.0 X 76.2 X 19.1 mm)
Case Material	Coated Metal with Non-Conductive Base
Shield Connection	
24V Input Models	Negative Input, Pin 3
48V Input Models	Positive Input, Pin 2
Flammability	UL94V-0
Weight	142 Grams

## OUTLINE DRAWING

### 6000UR

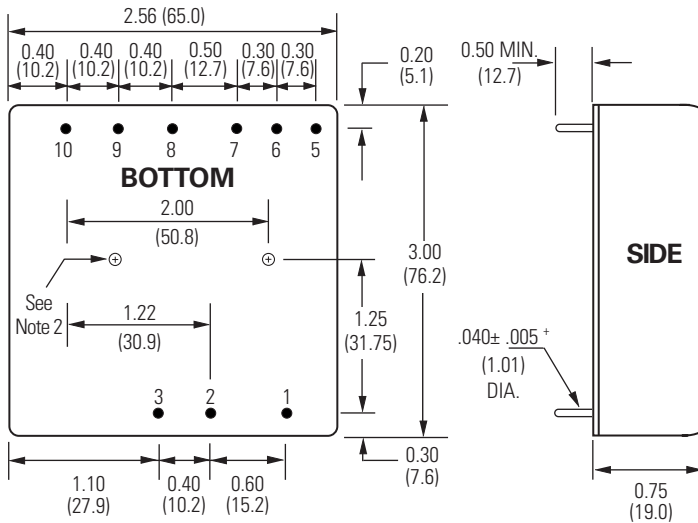

### PIN OUT CHART

Pin	Single	Dual	Triple
1	Remote On/Off	Remote On/Off	Remote On/Off
2	+ Vin	+ Vin	+ Vin
3	- Vin	- Vin	- Vin
5	+Sense/Trim	+ Vout	+ Vout (Aux)
6	Output Trim	Common	Common(Aux)
7	- Sense/Trim	- Vout	- Vout (Aux)
8	+ Vout	Output Trim	+5V Vout
9	- Vout	No Pin	- 5V Vout
10	No Pin	No Pin	Output Trim (Primary)

\* Connections for single output models without sensing or external trimming:  
For proper operation, externally connect Pin 5 (+Sense) to Pin 8 (+Vout)  
and Pin 7 (-Sense) to Pin 9 (-Vout)

+ The following pins are 0.08" (2.04 mm) in diameter:  
All models: Pins 2 & 3  
Single and Triple Outputs: Pins 8 & 9  
Dual Outputs: Pins 5, 6, & 7

### HEATSINK

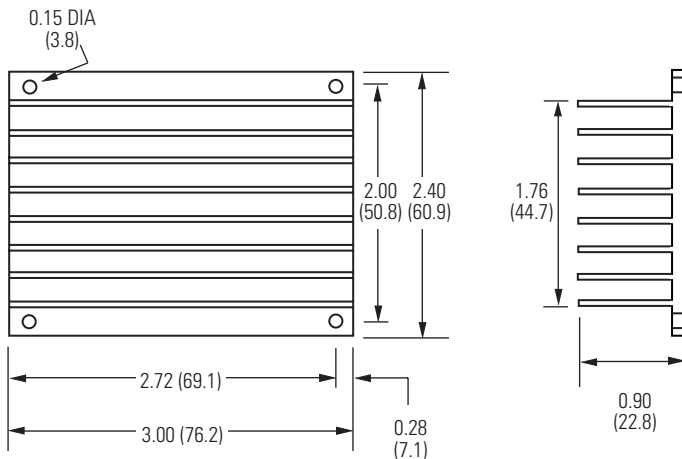

### Notes:

1. Unless otherwise specified dimensions are in inches (mm).

Tolerances	Inches	mm
	X.XX = ±0.02	X.X = ±0.5
	X.XXX = ±0.010	X.XX = ±0.25

2. Mounting inserts: 4-40 X .10 (2.5) Deep

All specifications are typical at nominal input, nominal load and 25° C unless otherwise specified.  
External, low ESR, 10 microfarad (minimum) capacitor across input is recommended for operation.

## How To ORDER

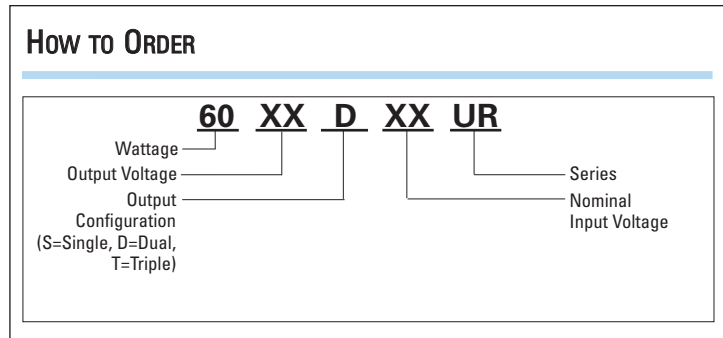

## MODEL SELECTION CHART

Model	Nominal Input Voltage (VDC)	Output Voltage (VDC)	Full Load Output Current (mA)	No Load Input Current (mA)	Full Load Input Current (mA)	Reflected Ripple Current (mA)	Output Over Voltage (VDC)	Efficiency @ FL (%)
6003S24UR	24	3.3	15000	40	2610	300	5.8	79
6005S24UR	24	5	10000	40	2670	240	6.8	78
6012S24UR	24	12	4166	40	2610	240	16.0	79
6015S24UR	24	15	3333	40	2610	240	18.0	79
6005D24UR	24	±5	±5000	40	2540	260	±6.8	80
6012D24UR	24	±12	±2000	40	2600	260	±16.0	77
6015D24UR	24	±15	±1660	40	2670	260	±18.0	77
6003S48UR	48	3.3	16580	40	1420	300	5.8	80
6005S48UR	48	5	10000	40	1360	240	6.8	76
6012S48UR	48	12	5000	40	1580	240	16.0	79
6015S48UR	48	15	4280	40	1670	240	18.0	80
6005D48UR	48	±5	±6250	40	1540	240	±6.8	83
6012D48UR	48	±12	±2500	40	1580	150	±16.0	79
6015D48UR	48	±15	±2000	40	1550	150	±18.0	80
6005/12T24UR	24	5, ±12	5000, ±1040	40	2600	240	6.8, ±15.0	83
6005/15T24UR	24	5, ±15	5000, ± 833	40	2430	240	6.8, ±18.0	83
6005/12T48UR	48	5, ±12	5000, ±1040	40	1200	240	6.8, ±15.0	84
6005/15T48UR	48	5, ±15	5000, ±1000	40	1400	240	6.8, ±18.0	85

## OUTPUT VOLTAGE ADJUSTMENT (6000UR SINGLE OUTPUT)

The converter's output voltage may be trimmed to  $\pm 10\%$  of the nominal output voltage.

### TRIM UP

Trim output voltage up by connecting an external resistor between Pins 6 and 7/9. Use the following equation. Reference Table 1 for variable A.

$$\text{Radj-up} = \frac{A}{\Delta \%} - 24 \text{ (k}\Omega\text{)}$$

#### Example:

If we want to trim 5% up for 12V output units, where  $A = 1.98$ ,  $\Delta \% = 0.05$

$$\text{Radj-up} = \frac{1.98}{0.05} - 24 \text{ k}\Omega = 15.6 \text{ k}\Omega$$

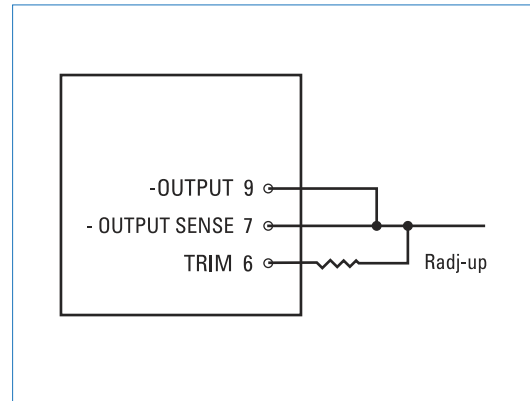

**Table 1.**

Output Voltage	A
3.3V	0.75
5V	1.25
12V	1.98
15V	2.08

### TRIM DOWN

Trim output voltage down by connecting an external resistor between Pins 6 and 5/8. Use the following equation. Reference Table 2 for variable C and D.

$$\text{Radj-down} = \frac{C}{\Delta \%} - D \text{ (k}\Omega\text{)}$$

#### Example:

If we want to trim 2% down for 5V output units, where  $C = 1.25$ ,  $D = 26.5$ ,  $\Delta \% = 0.02$

$$\text{Radj-down} = \frac{1.25}{0.02} - 26.5 \text{ k}\Omega = 36 \text{ k}\Omega$$

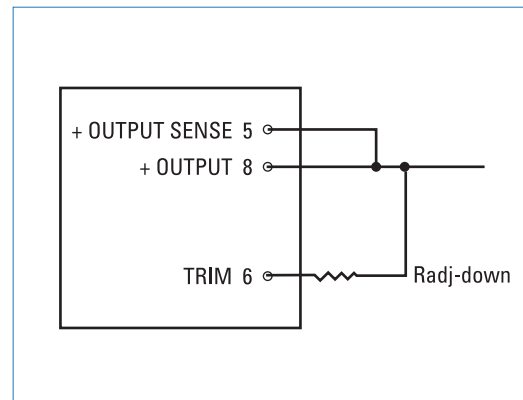

**Table 2.**

Output Voltage	C	D
3.3V	1.25	24
5V	1.25	26.5
12V	7.57	33.5
15V	10.3	36.4

## OUTPUT VOLTAGE ADJUSTMENT (6000UR DUAL OUTPUT)

The converter's output voltage may be trimmed to  $\pm 10\%$  of the nominal output voltage.

### TRIM UP

Trim output voltage up by connecting an external resistor between Pins 7 and 8. Use the following equation. Reference Table 1 for variable A.

$$\text{Radj-up} = \frac{A}{\Delta \%} - 24 \text{ (k}\Omega\text{)}$$

#### Example:

If we want to trim 5% up for 12V output units, where  $A = 2.23$ ,  $\Delta \% = 0.05$

$$\text{Radj-up} = \frac{2.23}{0.05} - 24 \text{ k}\Omega = 20.6 \text{ k}\Omega$$

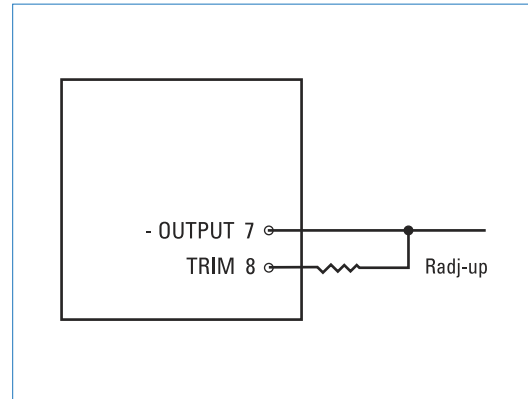

**Table 1.**

Output Voltage	A
5V	1.87
12V	2.23
15V	2.28

### TRIM DOWN

Trim output voltage down by connecting an external resistor between Pins 5 and 8. Use the following equation. Reference Table 2 for variable C and D.

$$\text{Radj-down} = \frac{C}{\Delta \%} - D \text{ (k}\Omega\text{)}$$

#### Example:

If we want to trim 5% down for 5V output units, where  $C = 5.63$ ,  $D = 31.5$ ,  $\Delta \% = 0.05$

$$\text{Radj-down} = \frac{5.63}{0.05} - 31.5 \text{ k}\Omega = 81.1 \text{ k}\Omega$$

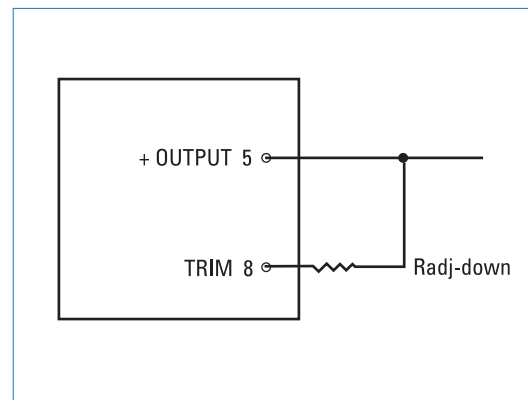

**Table 2.**

Output Voltage	C	D
5V	5.63	31.5
12V	19.3	45.5
15V	25.1	51.4

## OUTPUT VOLTAGE ADJUSTMENT (6000UR TRIPLE OUTPUT)

The converter's output voltage may be trimmed to  $\pm 10\%$  of the nominal output voltage.

### TRIM UP

Trim output voltage up by connecting an external resistor between Pins 9 and 10. Use the following equation.

$$\text{Radj-up} = \frac{1.25}{\Delta \%} - 24 \text{ (k}\Omega\text{)}$$

#### Example:

If we want to trim 5% up where  $\Delta \% = 0.05$

$$\text{Radj-up} = \frac{1.25}{0.05} - 24 \text{ k}\Omega = 1 \text{ k}\Omega$$

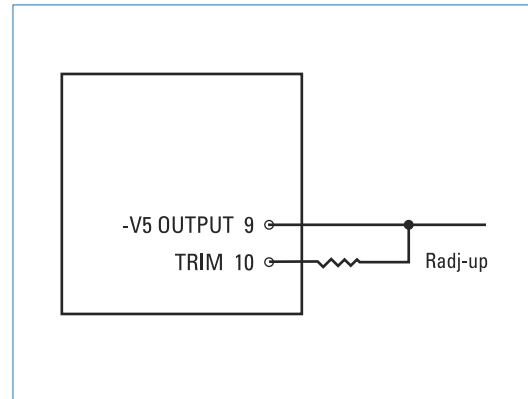

### TRIM DOWN

Trim output voltage down by connecting an external resistor between Pins 8 and 10. Use the following equation.

$$\text{Radj-down} = \frac{1.25}{\Delta \%} - 26.5 \text{ (k}\Omega\text{)}$$

#### Example:

If we want to trim 2% down where  $\Delta \% = 0.02$

$$\text{Radj-down} = \frac{1.25}{0.02} - 26.5 \text{ k}\Omega = 36 \text{ k}\Omega$$

